

OPERATING, INSTALLATION, AND MAINTENANCE MANUAL FOR THE GULF COAST TANKLESS WATER HEATER

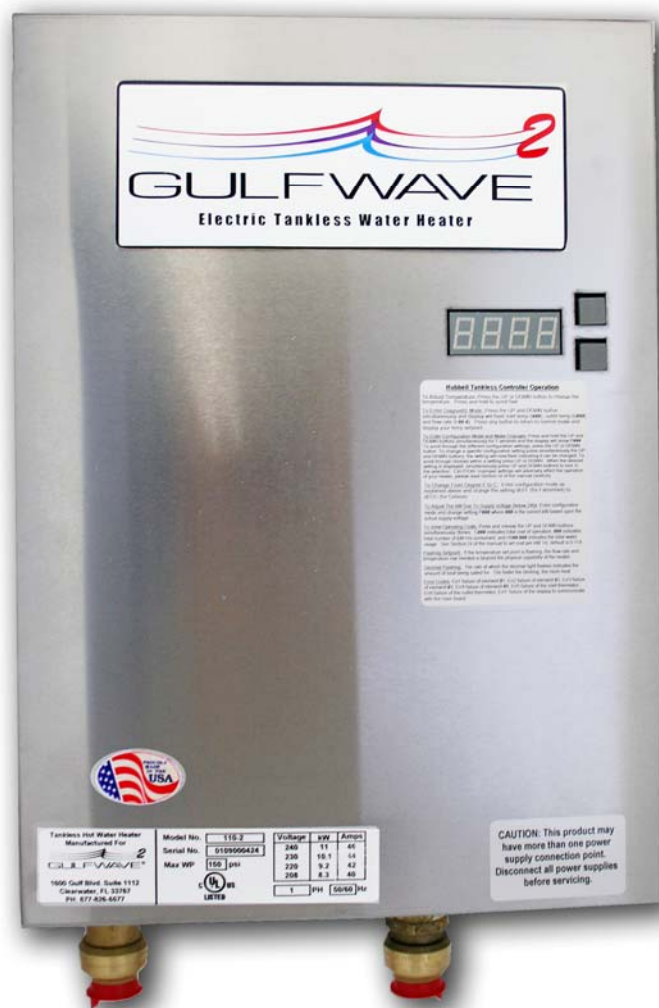

**The Wave of the Future
Gulf Coast Tankless Hot Water of Clearwater, Inc.**



**GULF COAST TANKLESS HOT WATER
1600 GULF BLVD. SUITE 1112
CLEARWATER, FL 33637**

PHONE: (727) 517-2113

INTERNET: www.gulfcoasttanklesswaterheaters.com

 **Important Safety Information**

1. You must read and follow all instructions. Serious bodily injury or death could occur if you ignore this warning.
2. All circuit breakers and/or disconnect switches servicing the heater must be turned off when installing, uninstalling, or repairing this water heater.
3. The Gulf Coast Tankless Water Heater must be grounded.
4. The unit must be installed by a licensed electrician and plumber.
5. The unit must be wired in accordance with the current version of the National Electrical Code (US) or Canadian Electric Code (Canada).
6. This installation must comply with all national, state, and local plumbing and electrical codes.
7. When the heater is not within sight of the electrical circuit breakers, an additional local means of disconnection of all ungrounded conductors must be provided that is within sight of the appliance or a circuit breaker lockout must be used. (Ref. NEC 422.31)
8. If the Gulf Coast Tankless Water Heater is installed in a location where water damage could occur in the event of a leak, it is recommended that a drip pan be installed and connected to a suitable drain. Alternatively, an active water leak detector and shut off valve can be installed to turn off your water supply in the event a leak is detected.
9. If water supply has a high mineral content, a water softening system is recommended. Damage to the water heater resulting from scale or hard minerals will not be covered under warranty.

TABLE OF CONTENTS

SECTION	TITLE	PAGE No.
I	TANKLESS WATER HEATER OPERATING PRINCIPLE	4
II	GENERAL DESCRIPTION AND CONSTRUCTION	6
III	INSTALLATION	9
IV	OPERATION AND MAINTENANCE	13
V	TROUBLESHOOTING	16
VI	SERVICING & REPLACEMENT OF PARTS	21
VII	PARTS LIST	25
VIII	WARRANTY	26

SECTION I – TANKLESS WATER HEATER OPERATING PRINCIPLE

How the Gulf Coast Tankless Water Heater Works:

For the most part, operating your new tankless water heater is very similar to using any traditional water heater system. However, it is very important that you carefully read all of the set-up procedures and operating instructions to ensure maximum performance and energy savings from your new water heater.

Your Gulf Coast Tankless Water Heater does not store hot water like a conventional tank-type water heater. It contains high powered heating elements that are capable of heating water instantly on-demand as you need it. As soon as you turn on a hot water faucet, a sophisticated flow sensor recognizes that you have turned on the water. This sensor measures the water flow rate while two other sensors measure the incoming and outgoing water temperature. This information is transmitted continually to the microprocessor controller which determines the precise amount of power to send to the heating elements to heat the water to your desired temperature. The Gulf Coast tankless water heater only uses as much power as is needed to meet the demand by fully modulating the heating elements from 0 to 100%. Since your new water heater works on a demand basis, it will absolutely never run out of hot water no matter how many back to back showers you run!

It is important to keep in mind that all tankless water heaters are subject to a maximum flow rate. If you exceed this flow rate, the heater will not be capable of fully heating water. How much water you will be able to demand from your tankless water heater at any given time will depend on the model you have selected and your incoming water temperature. If you live in an area of the country where inlet water temperature average 55° F or you have cold winters, you will probably NOT be able to run multiple large water demand fixtures at the same time. However, you will be able to run all your hot water applications back to back without ever having to wait. You will enjoy UNLIMITED HOT WATER. See the charts in Section II to determine the maximum flow rates.

Moreover, since a tankless water heater eliminates the ongoing thermal losses caused by storing hot water in a tank, you will enjoy significant energy savings over a conventional water heater.

When you use hot water in your home with a conventional water heater, you need to mix a considerable volume of cold water to cool the hot water down to a safe, comfortable level. You need to do this with a traditional tank-type water heater because they are set at an extremely high temperature to prevent them from running out of hot water quickly. With a tankless water heater, you typically set the temperature at a much lower level since it is capable of heating your water on demand. This level will be much closer to the actual temperature at which you feel comfortable showering or bathing. As such, you will no longer need to mix much cold water to run a shower or bath; in fact, you may mix very little or no cold water. This is perfectly normal and means that you are no longer wasting energy by overheating your water.

Product Overview:

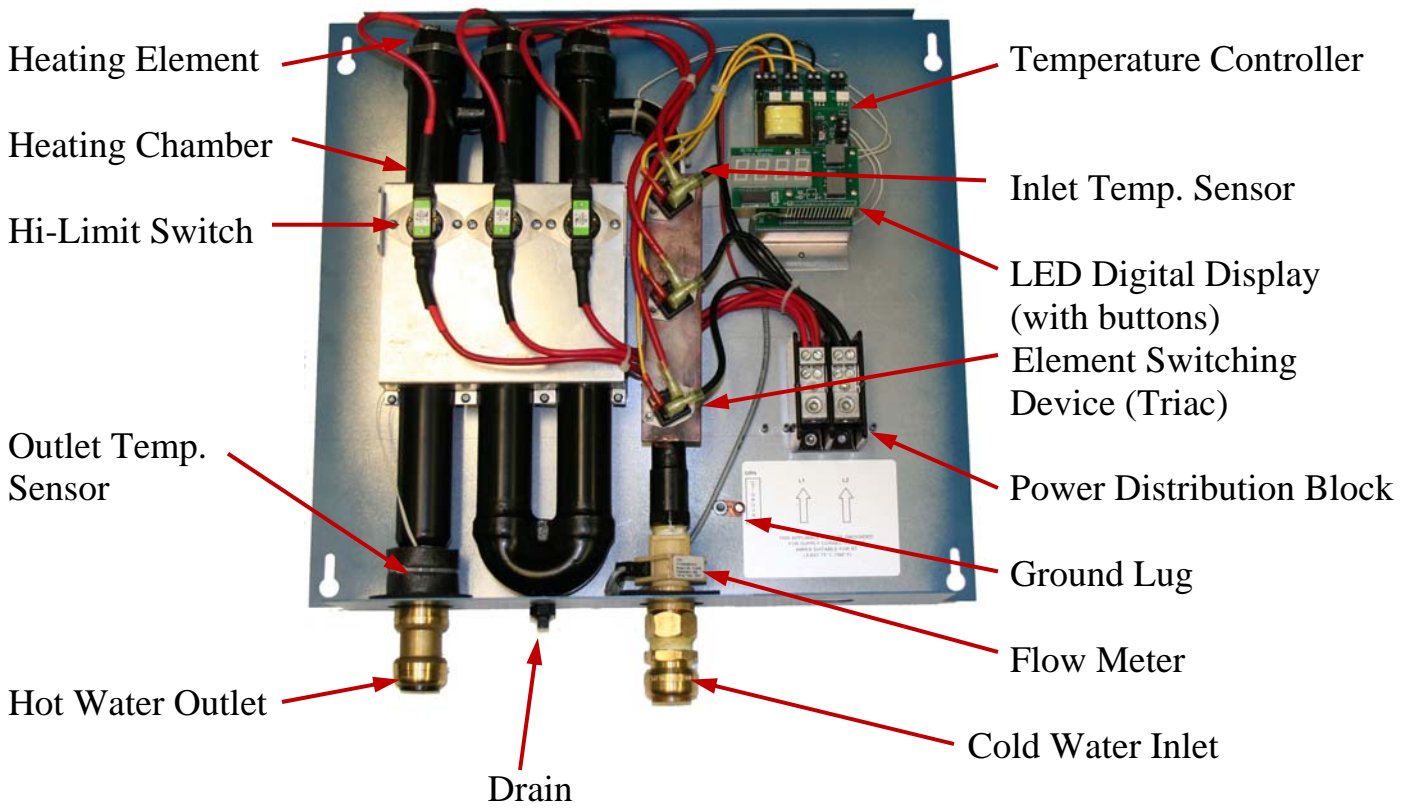

Hubbell Tankless Water Heater Selection Overview:

Model No.	kW	Amps @ 240V	Min. Required Home Service (Amps)	Max. flow (GPM) of water heated to 105°F with incoming cold water of						
				45	50	55	60	65	70	75
G-27	27	112.5	200	3.1	3.4	3.7	4.1	4.6	5.3	6.2
G-24	24	100.0	200	2.7	3	3.3	3.6	4.1	4.7	5.5
G-21	21	87.5	200	2.4	2.6	2.9	3.2	3.6	4.1	4.8
G-18	18	75.0	150	2.1	2.2	2.5	2.7	3.1	3.5	4.1
G-16	16	66.7	125	1.8	2	2.2	2.4	2.7	3.1	3.6
G-14	14	58.3	100	1.6	1.7	1.9	2.1	2.4	2.7	3.2
G-11	11	45.8	100	1.3	1.4	1.5	1.7	1.9	2.1	2.5

Tankless Pressure Drop Chart:

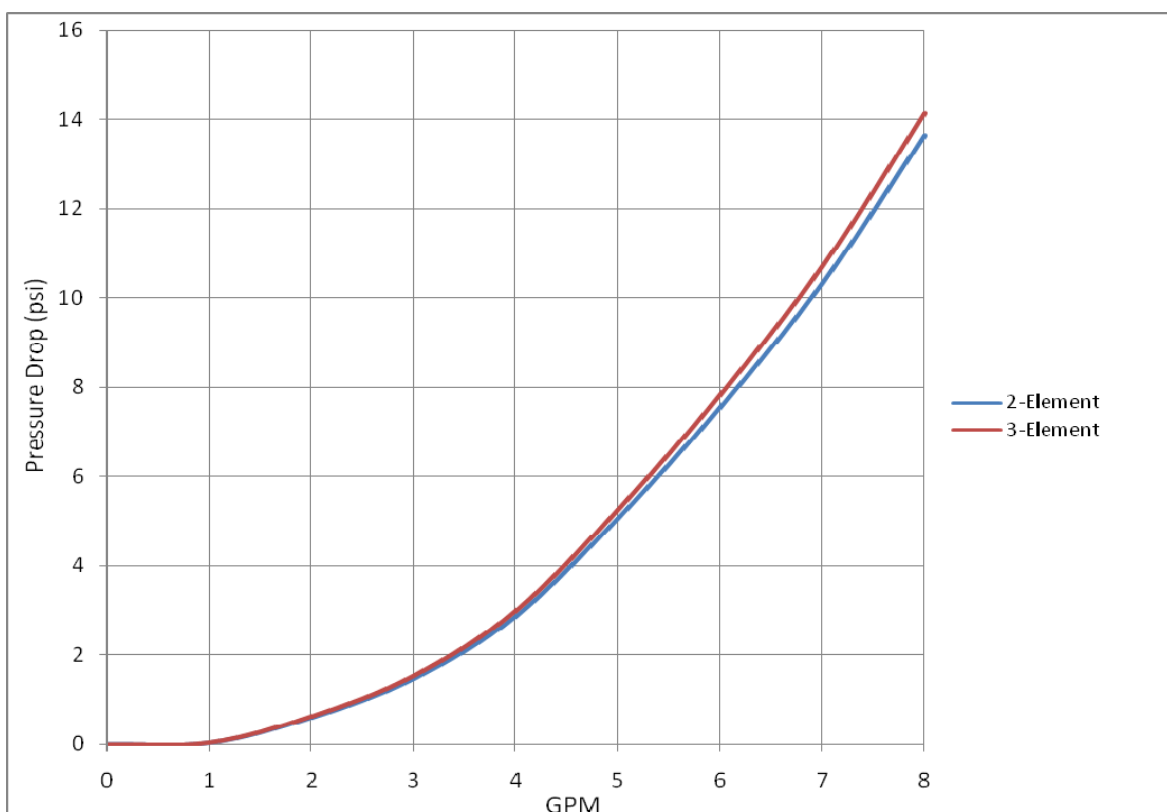

SECTION II – GENERAL DESCRIPTION AND CONSTRUCTION

Technical Specifications Common to All Models:

Materials:	Copper Exchanger / Aluminum Casing	Plumbing Connection:	¾" Copper, CPVC, or PEX
Voltage:	208-240 Volts / 1 Ph	Operating Range:	5 – 150 psi
Frequency:	50 / 60 Hz	Protection:	Thermal Auto Reset
Energy Efficiency:	99.5%		

Model G-27

The most powerful electric tankless water heater on the market. This 27 KW water heater is configured for cold climates where the incoming water temperature can drop below 45° F. The Model G-27 is well suited for homes in the northern U.S. and Canada, and those in the southern U.S. that have large Roman-style or Jacuzzi tubs and that have generally more demanding water usage needs.

		Maximum Flow Rate (GPM)					
		Outlet Temp. (°F)					
		100	105	110	115	120	125
Inlet Temp. (°F)	45	3.4	3.1	2.8	2.6	2.5	2.3
	50	3.7	3.4	3.1	2.8	2.6	2.5
	55	4.1	3.7	3.4	3.1	2.8	2.6
	60	4.6	4.1	3.7	3.4	3.1	2.8
	65	5.3	4.6	4.1	3.7	3.4	3.1
	70	6.2	5.3	4.6	4.1	3.7	3.4
	75	7.4	6.2	5.3	4.6	4.1	3.7

Technical Specifications:

Dimensions:	17" x 16" x 3"	Customer Double-Pole Main Breaker / Fused Disconnect Required:	1 x 125A or 2 x 60A or 3 x 40A
Weight:	23 lbs.		
kW / Elements:	27 kW / 3 elements		
Max. Amps:	112.5 A @ 240 V		

Model G-24

The 24 KW water heater is configured for climates where incoming water temperatures are in the 50° - 70° F range. The Model G-24 is suitable as a whole house water heater.

		Maximum Flow Rate (GPM)					
		Outlet Temp. (°F)					
		100	105	110	115	120	125
Inlet Temp. (°F)	45	3	2.7	2.5	2.3	2.2	2.1
	50	3.3	3	2.7	2.5	2.3	2.2
	55	3.6	3.3	3	2.7	2.5	2.3
	60	4.1	3.6	3.3	3	2.7	2.5
	65	4.7	4.1	3.6	3.3	3	2.7
	70	5.5	4.7	4.1	3.6	3.3	3
	75	6.6	5.5	4.7	4.1	3.6	3.3

Technical Specifications:

Dimensions:	17" x 16" x 3"	Customer Double-Pole Main Breaker / Fused Disconnect Required:	1 x 110A or 2 x 60A or 3 x 40A
Weight:	23 lbs.		
kW / Elements:	24 kW / 3 elements		
Max. Amps:	100 A @ 240 V		

Model G-21

The 21 KW, water heater is configured for cold climates where the incoming water temperature can drop below 55° F. The Model G-21 is well suited for homes in the northern U.S. and Canada, and those in the southern U.S. that have large Roman-style or Jacuzzi tubs and that have generally more demanding water usage needs.

		Maximum Flow Rate (GPM)					
		Outlet Temp. (°F)					
		100	105	110	115	120	125
Inlet Temp. (°F)	45	2.7	2.5	2.3	2.1	2	1.9
	50	3	2.7	2.5	2.3	2.1	2
	55	3.3	3	2.7	2.5	2.3	2.1
	60	3.8	3.3	3	2.7	2.5	2.3
	65	4.3	3.8	3.3	3	2.7	2.5
	70	5	4.3	3.8	3.3	3	2.7
	75	6	5	4.3	3.8	3.3	3

Technical Specifications:

Dimensions:	17" x 16" x 3"	Max. Amps:	87.5 A @ 240 V
Weight:	23 lbs.	Customer Double-Pole Main Breaker Required:	1 x 100A or 2 x 50A
kW / Elements:	21 kW / 3 elements		

Model G-18

The 18 KW water heater is configured for climates where incoming water temperatures are in the 60° -70° F range. The Model G-18 is suitable as a whole house water heater.

		Maximum Flow Rate (GPM)					
		Outlet Temp. (°F)					
		100	105	110	115	120	125
Inlet Temp. (°F)	45	2.2	2.1	1.9	1.8	1.6	1.5
	50	2.5	2.2	2.1	1.9	1.8	1.6
	55	2.7	2.5	2.2	2.1	1.9	1.8
	60	3.1	2.7	2.5	2.2	2.1	1.9
	65	3.5	3.1	2.7	2.5	2.2	2.1
	70	4.1	3.5	3.1	2.7	2.5	2.2
	75	4.9	4.1	3.5	3.1	2.7	2.5

Technical Specifications:

Dimensions:	13 ½" x 16" x 3"	Max. Amps:	75 A @ 240 V
Weight:	19 lbs.	Customer Double-Pole	1 x 80A or
kW / Elements:	18 kW / 2 elements	Main Breaker Required:	2 x 40A

Model G-16

The 16 KW Model G-16 is designed for moderate climates where the coldest incoming water temperature is 60° F or greater. As a whole house model, the Model G-16 is best suited to homes in the southernmost regions of the U.S. (i.e. Southern California, Texas, Florida, etc.), as well as Mexico, and the Caribbean.

		Maximum Flow Rate (GPM)					
		Outlet Temp. (°F)					
		100	105	110	115	120	125
Inlet Temp. (°F)	45	2	1.8	1.7	1.6	1.5	1.4
	50	2.2	2	1.8	1.7	1.6	1.5
	55	2.4	2.2	2	1.8	1.7	1.6
	60	2.7	2.4	2.2	2	1.8	1.7
	65	3.1	2.7	2.4	2.2	2	1.8
	70	3.6	3.1	2.7	2.4	2.2	2
	75	4.4	3.6	3.1	2.7	2.4	2.2

Technical Specifications:

Dimensions:	13 ½" x 16" x 3"	Max. Amps:	67 A @ 240 V
Weight:	19 lbs.	Customer Double-Pole	1 x 80A or
kW / Elements:	16 kW / 2 elements	Main Breaker Required:	2 x 40A

Model G-14

The 14 KW Model G-14 tankless water heater is configured for climates where the lowest incoming water temperature is above 70° F. The Model G-14 is used primarily in warm climates as a whole house unit in tropical climates.

		Maximum Flow Rate (GPM)					
		Outlet Temp. (°F)					
		100	105	110	115	120	125
Inlet Temp. (°F)	45	1.7	1.6	1.5	1.4	1.3	1.2
	50	1.9	1.7	1.6	1.5	1.4	1.3
	55	2.1	1.9	1.7	1.6	1.5	1.4
	60	2.4	2.1	1.9	1.7	1.6	1.5
	65	2.7	2.4	2.1	1.9	1.7	1.6
	70	3.2	2.7	2.4	2.1	1.9	1.7
	75	3.8	3.2	2.7	2.4	2.1	1.9

Technical Specifications:

Dimensions:	13 ½" x 16" x 3"	Max. Amps:	59 A @ 240 V
Weight:	19 lbs.	Customer Double-Pole	1 x 70A or
kW / Elements:	14 kW / 2 elements	Main Breaker Required:	2 x 35A

Model G-11

The 11 KW Model G-11 tankless water heater is designed for moderate climates where the lowest incoming water temperature is above 70° F. The Model G-11 is a point of use or booster model in warm climates as opposed to a whole house water heater.

		Maximum Flow Rate (GPM)					
		Outlet Temp. (°F)					
		100	105	110	115	120	125
Inlet Temp. (°F)	45	1.4	1.3	1.2	1.1	1	0.9
	50	1.5	1.4	1.3	1.2	1.1	1
	55	1.7	1.5	1.4	1.3	1.2	1.1
	60	1.9	1.7	1.5	1.4	1.3	1.2
	65	2.1	1.9	1.7	1.5	1.4	1.3
	70	2.5	2.1	1.9	1.7	1.5	1.4
	75	3	2.5	2.1	1.9	1.7	1.5

Technical Specifications:

Dimensions:	13 ½" x 16" x 3"	Max. Amps:	46 A @ 240 V
Weight:	19 lbs.	Customer Double-Pole	1 x 50A or
kW / Elements:	11 kW / 2 elements	Main Breaker Required:	2 x 25A

Alternate Voltage Table

The tables below lists the power in kW and the amperages for each model when connected to voltages other than 240 volts.

		Power (kW)		
		Connected Voltage		
		208	220	230
Model No.	280-3	20.28	22.69	24.80
	240-3	18.03	20.17	22.04
	220-3	15.77	17.65	19.29
	180-2	13.52	15.13	16.53
	165-2	12.02	13.44	14.69
	145-2	10.52	11.76	12.86
	110-2	8.26	9.24	10.10

		Amperage		
		Connected Voltage		
		208	220	230
Model No.	280-3	97.50	103.13	107.81
	240-3	86.67	91.67	95.83
	220-3	75.83	80.21	83.85
	180-2	65.00	68.75	71.88
	165-2	57.78	61.11	63.89
	145-2	50.56	53.47	55.90
	110-2	39.72	42.01	43.92

Wattage De-rating Formula:

$$\frac{\text{Applied Voltage}^2}{\text{Rated Voltage}^2} \times \text{Rated Wattage} = \text{Actual Wattage}$$

For example: If installing a 27 kW unit, Model G-27, when actual voltage is 212 V,

$$\frac{212^2}{240^2} = \frac{44,944}{57,600} = 0.78 \times 27,000 \text{ W} = 21,060 \text{ W @ 212 V}$$

Amperage Formula:

$$\frac{\text{Watts}}{\text{Volts}} = \text{Amps (Single Phase)}$$

Flow Rate Formulas:

To determine power (kW) requirement

$$\text{___ GPM} \times \text{___ } ^\circ\text{F } \Delta\text{T} \times 0.1465 = \text{___ kW}$$

To determine temperature rise

$$\text{___ kW} \times \text{___ } 6.824 \div \text{___ GPM} = \text{___ } ^\circ\text{F } \Delta\text{T}$$

To determine flow rate

$$\text{___ kW} \times \text{___ } 6.824 \div \text{___ } ^\circ\text{F} \Delta\text{T} = \text{___ GPM}$$

SECTION III – INSTALLATION

WARNING: Serious bodily injury or death may occur if the following warnings are ignored.

- All circuit breakers and/or disconnect switches servicing this heater must be turned off before installing, repairing or uninstalling this water heater.
- Installation of this product is restricted to indoor locations.
- Installation **MUST** be done by a licensed electrician and licensed plumber.

Locating and Mounting Instructions:

Your tankless water heater can be installed just about anywhere! Due to the small size of your water heater, it can be mounted in many small spaces, including closets, under sinks, in pantries, or under stair storage areas. However, there are some important guidelines to follow that will ensure that your installation is both safe and convenient in the event that future servicing is required.

This product is designed to be installed indoors only. You may be able to install your unit in an outdoor location as long as it is mounted in a suitable enclosure that protects it from rain, splashed water, direct sunlight, debris and insects. This product should NOT be installed in a location where it may be subjected to freezing temperatures. If the water inside your tankless water heater freezes, it can cause severe and permanent damage that is not covered under your warranty. If you suspect that your tankless water heater may have frozen, do not turn on the heater until it has thawed and you have inspected the system for leaks.

When selecting an installation location, give consideration to your existing plumbing configuration, location of your main electrical panel, and location of your bathroom, kitchen and laundry area. Try to choose a location that does not require you to make major plumbing alterations, that is close to your main electrical panel (this will reduce the amount of wire that you need to install), and that is physically close to the hot water applications (faucets) that you use most often. By locating the heater close to the points-of-use, you will reduce the amount of time it takes for the hot water to travel from the water heater to your faucet. You should also give consideration to future servicing. Do NOT locate the water heater in a location that is difficult to access. In most cases, installing your tankless water heater in the same location as your old conventional tank-type water heater will make the most sense.

You should avoid installing your tankless water heater in a location prone to excessive humidity, moisture, or dust, or in an area where it may be splashed with water or other liquids. Do NOT install under water pipes or air conditioning lines that might leak or condense moisture that could then drip onto the heater. Do NOT install above electrical boxes or junctions.

If you plan to install your water heater on a second floor or in a heated attic space, make sure that you follow all code requirements for such installations as required for your area. We recommend that you install a drip pan (connected to a drain) below the water heater to avoid property damage in the unlikely event of a leak. Alternatively, you can install an active water leak detector and shut-off valve designed to turn off your water supply in the event that a leak is ever detected.

Mounting the unit:

- Leave a minimum of 4” to both sides and 12” on the top and bottom of the unit.
- Mount the water heater securely to the wall by putting four (4) screws through the mounting holes.

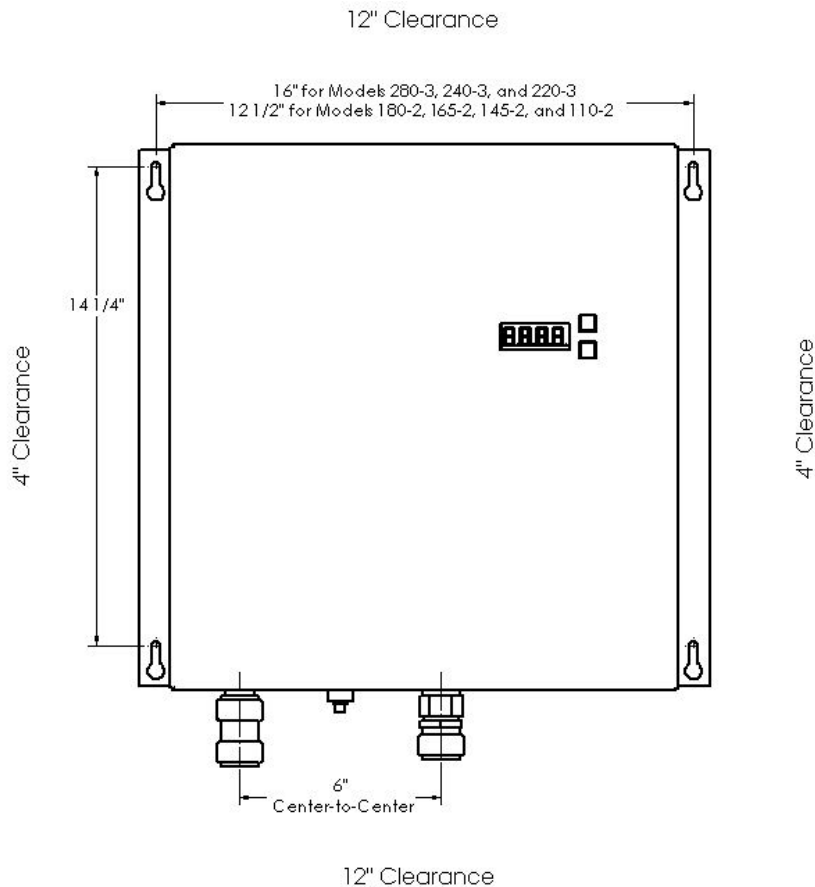

Plumbing Installation Instructions:

IMPORTANT INFORMATION:

- Ensure all fitting installations comply with local plumbing and building codes.
- This water heater does not require a temperature and pressure (T&P) relief valve. You may install a T&P relief valve if the county, city or state plumbing code requires it.
- Installations in the Commonwealth of MASSACHUSETTS and KENTUCKY require a T&P relief valve.
- When connecting to a plumbing system that utilizes Flex or PVC, a T&P relief valve should be used as added safety.
- Do not connect directly to CPVC pipe.
- Before energizing the heater, run water for a minimum of 3 minutes and verify that all air has been removed.

Preparation:

- You must use at least three feet of copper pipe prior to connecting to any CPVC connection.
- A shut off valve **MUST** be installed on inlet side of unit. A shut off valve on the outlet is recommended.

Cutting the Pipe:

- Cut the tube so that the ends are square. **WARNING:** Ensure that there are no burrs or damage to the cut end. This will eliminate any damage to the internal o-ring.
- Once the tubing end is cut square and clean, use the SharkBite Depth Gauge (not supplied by Gulf Coast) and a scribe to mark the insert depth on the outside of the tubing
- Check that fittings and tubing are clean, in good condition and are free from damage and foreign objects.

Soldering:

- **WARNING:** Do not solder any pipes with the unit connected to pipes. Failure to do this will damage the flow meter and void your warranty.

Flushing the Line:

- Before connecting the copper to the water heater, it is extremely important to flush the lines to eliminate all plumbing paste, residue, or debris in the lines.

Installation of SharkBite:

- The SharkBite connection system uses an advanced push-fit design that works in two stages. When the tube is inserted into the fitting it passes the first stage through a release collar and then through a stainless steel grab ring. The grab ring has teeth that open out and grip onto the tube. At the second stage the tube is pushed through an o-ring protector which aligns the tube. A specially formulated o-ring is then compressed between the wall of the fitting and the tube before the end of the tube reaches the tube stop.
- To assemble correctly, the tubing needs to be pushed into the fitting until it meets the tube stop. Push the tube firmly with a slight twisting action until it reaches the tube stop.
- Connect the cold water line to the water heater inlet marked cold water. Connect the hot water line to the water heater outlet marked hot water.
- To ensure that the tube is correctly inserted, check that the depth mark is within 0.05 in (1.3 mm) of the end of the release collar.
- After inserting both fittings, open the hot water faucet and allow water to run through the water heater for at least ten (10) minutes, cycling the flow on and off every minute. This process clears all the air from the lines and must be performed prior to turning on the power at the unit. **WARNING:** Failure to do this will damage the flow meter or heating elements and void your warranty.

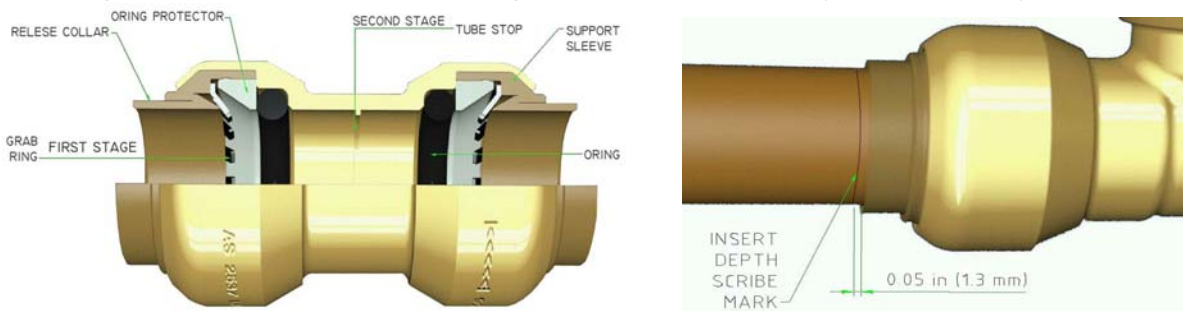

Disconnecting a Joint:

- Disconnection of the joint can only occur by using either the SharkBite disassembly clip or the SharkBite disconnecting fork tool. By applying pressure to the release collar with the clip or the fork tool, the grab ring teeth are splayed. This action releases the tube, allowing it to be removed from the fitting.
- Place the SharkBite disassembly clip around the tube with the non-branded face against the release collar. If using the SharkBite fork tool, place the forks around the fitting assembly. The fork end with the SharkBite brand logo should be positioned around the tube and the other end around the neck of the fitting.
- Push the clip against the release collar and pull the tube with a twisting action to release the tube. If using the SharkBite fork tool, squeeze the tool with one hand and pull the tube with a twisting action to release the tube.
- Check the fitting and tube end for damage. The fitting should be free of damage and foreign objects. The tubing should be free of damage and marks on the outside diameter. If the tubing is damaged or marked, then cut and use a new section of tubing.

Checking for Leaks and Purging Air:

- If unit has been wired, verify all circuit breakers supplying power to the unit are turned off.
- Open all hot water taps supplied by the unit and inspect water connections for leaks.
- **With all hot water taps still open, allow the water to run for a minimum of 3 minutes.** Inspect each tap to ensure all air in the lines has been purged. This process purges all the air from the water lines and **MUST** be performed prior to turning on the power at the unit. **WARNING:** FAILURE TO FOLLOW THIS STEP CAN CAUSE PERMANENT DAMAGE TO THE HEATING ELEMENTS.
- Close all hot water taps.

Electrical Installation Instructions:

IMPORTANT INFORMATION:

- The unit must be wired in accordance with the current version of the National Electrical Code (US) or Canadian Electric Code (Canada).
- The unit must have its own independent circuits.
- When the heater is not within sight of the electrical circuit breakers, an additional local means of disconnection of all ungrounded conductors must be provided that is within sight of the appliance or a circuit breaker lockout must be used. (Ref. NEC 422.31)
- Wire entry must be through the electrical KO provided in the bottom of the unit.
- For Canada, per Canadian Electric Code, C22.1-02, the unit must be wired by a single feed installation with one (1) double-pole circuit breaker.
- For US, the unit may be wired by a single feed installation with one (1) double-pole circuit breaker or by a multiple feed installation with double-pole circuit breakers as shown below.

Wiring to the water heater:

- Connect the power wire from the main panel to the power distribution block.
- Connect the main ground wire to the ground lug in the heater.
- Make sure the connections are securely tightened.

Electrical Specifications:

Hubbell Tankless Model No.	110-2	145-2	165-2	180-2	220-3	240-3	280-3
kW @ 240V	11	14	16	18	21	24	27
Amps @ 240V	45.8	58.3	66.7	75.0	87.5	100.0	112.5
Min. Recommended Amperage to Home	100	100	125	150	200	200	200

Multiple Circuit Installation:

Minimum Double-Pole Circuit Breaker Size (quantity x amps) (US only)	2x25	2x35	2x40	2x40	2x50	2x60	2x60
						3x40	3x40
Min. Feed Wire Size at 75°C THHN or Equivalent	8	8	8	8	8	6	6
						8	8

Single Circuit Installation:

Minimum Double-Pole Circuit Breaker Size (US and Canada)	50	70	80	80	100	110	125
Min. Feed Wire Size at 75°C THHN or Equivalent	8	6	4	4	3	2	1

- Tankless water heaters are considered a non-continuous load.
- If 3 circuits are used, it is acceptable to install two conductors in one line side port and the third conductor in the second line side port of the power distribution block. Alternatively, one conductor may be installed in each line side port and the third conductor in an open load side port of the power distribution block.
- 60°C or 90°C wire may be used. Refer to NEC table 310.16 for sizing.
- Conductors should be sized to maintain a voltage drop of less than 3% under load.

Alternate Voltage Configuration Settings:

- The unit is factory configured and optimized for 240 volts. If the actual voltage supplied is less or equal to 230 volts, set the power factor in the configuration menu (see Temperature Controller User Interface Instructions in Section IV) according to the Alternate Voltage Table on page 8.

SECTION IV – OPERATION AND MAINTENANCE

Using the Gulf Coast Tankless Water Heater:

- The user controls on your new tankless water heater are very easy to operate. The digital display will show your current set water temperature at all times that the water heater is running.
- Once power is turned on at the main panel, adjust the outlet temperature by pressing either the upper or lower buttons as required until the desired temperature is displayed.
- The upper button will increase the temperature and the lower button will decrease the temperature.
- The unit is now automatic in operation. When water flows through the unit, the heater will turn on to heat the water. When the flow of water stops, the heater will shut off.
- NOTE: The digital display will always remain lit as long as power from the main panel is applied.

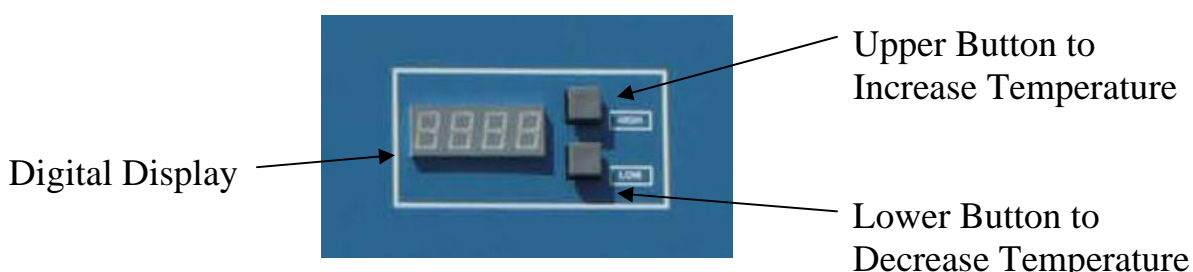

- Most people feel comfortable showering or bathing at a temperature between 98° and 105°F (37° to 41°C). We recommend that you set the output water temperature of your water heater in the range of 105° - 110°F (approx. 41° - 43°C). This will ensure you have adequate hot water to meet all of your household needs while also maximizing your available water flow rate, reducing the risk of scalding to children and the elderly, and increasing the energy savings you achieve.
- NOTE: All newer model dish washing machines are equipped with an internal heating element, and most clothes washing detergents are now designed for use in cold and warm water. There is no longer a need to set your water heater to a temperature above 125°F. Temperatures above this level (which most traditional water heaters are set to deliver) can cause serious scalding injuries to small children or elderly persons in your home.
- If a water leak is detected from your water heater, turn off the water supply at the shut-off valve on the inlet side of the water heater, turn off the power to the heater at the main electrical panel and call a service technician or plumber for evaluation and repair.
- When any maintenance is performed on the water heater or the home's plumbing system that may introduce air into the plumbing pipes, it is important to turn the power off to the water heater and purge the air out of the lines before allowing the unit to power up. See Checking for Leaks and Purging Air in Section III.

Maintenance:

- The Gulf Coast Tankless Water Heater requires no maintenance other than to periodically check around the outside of the unit for leaks.

Temperature Controller User Interface Instructions:

1. The display is always on when power is applied to the unit:
 - a. To turn the unit OFF, press and hold the DOWN button until the display shows OFF.
 - b. Note that the controller will resume its last mode of operation if power is disconnected.
2. To change setpoint temperature (the temperature is fully adjustable in 1° increments).

- a. Press the UP or DOWN button to change the setpoint temperature.
 - b. Pressing and holding either the UP or DOWN button will fast scroll.
3. Configuration Menu.
- a. To enter configuration menu, press and hold the UP and DOWN buttons simultaneously for 10 seconds. (Note that the display will change during the time you are holding the buttons. You are in the configuration menu and can release the buttons when the first character of the display is 'P').
 - b. To scroll through menu settings, press the UP or DOWN button.
 - c. To make a change to a specific configuration setting press simultaneously the UP and DOWN button, the setting will now flash indicating it can be changed.
 - d. To scroll through optional settings within a menu press the UP or DOWN key.
 - e. When the desired setting is displayed, simultaneously press the UP and DOWN button to lock in the selection and return back to the menu settings.
 - f. Settings:
 - i. Power Setting - Sets the total kW rating of water heater.
 - 1. P###, where ### is adjustable from 001 to 028 (Note that the kW selection should equal the kW based upon the actual voltage measured to the heater. Please see the nameplate on the front cover of the heater for a listing of kW ratings at various voltages).
 - ii. Temperature Range – Sets the temperature adjustment range
 - 1. r001, 60° to 140°F (15°-60°C) (Factory Default)
 - 2. r002, 32° to 194°F (0°-90°C)
 - 3. r003, 32° to 104°F (0°-40°C)
 - iii. Display units – Sets the display units to either Fahrenheit/Gallons or Celsius/Liters.
 - 1. dEFF, for degrees Fahrenheit and Gallons. (Factory Default)
 - 2. dECC, for degrees Celsius and Liters.
 - iv. Display Style– Sets the display to show various values.
 - 1. dSP1, to display setpoint temperature only. (Factory Default)
 - a. setpoint is displayed as ###
 - 2. dSP2, to display measured inlet temperature intermittently with setpoint temperature.
 - a. Inlet temperature is displayed as i###
 - 3. dSP3, to display measured outlet temperature intermittently with setpoint temperature.
 - a. Outlet temperature is displayed as o###
 - 4. dSP4, to display measured flow rate intermittently with setpoint temperature
 - a. Flow rate is displayed as F###
 - 5. dSP5, to display inlet temp, outlet temp, flow rate and setpoint all intermittently.
 - v. Power Limiting Factor – Sets the % of heater output allowed by the controller
 - 1. L###, where ### is a percentage from 001 to 100 (Factory Default 100). This feature allows a user to limit the kW rating of the unit by a specific percentage and effectively lower the total amp draw of the unit.
 - vi. Heater Quantity – Sets the controller to perform calculations using the number of heating elements in the unit.
 - 1. E001, for one heating element and all 3-phase units
 - 2. E002, for two heating elements
 - 3. E003, for three heating elements
 - 4. E004, for four heating elements
 - vii. Software Version – Displays the version number of the software
 - 1. Sd##, where ## is the version of the display software.

2. Sb##, where ## is the version of the main board software.
- g. To leave the configuration menu, wait 7 seconds without pushing any buttons.
4. Diagnostic Menu Display
 - a. To display common diagnostic data useful for troubleshooting, when in normal display mode press and release the UP and DOWN buttons simultaneously.
 - b. The display will intermittently display the following values: flow rate (F###), measured inlet temp (i###), measured outlet temp (o###), setpoint (###).
 - c. These values and settings will continue to display and scroll until either the UP or DOWN button is pressed and will then return to normal display mode.
5. Configuration Settings Display
 - a. To display all configuration settings, when in normal display mode press and release the UP and DOWN buttons simultaneously twice.
 - b. The display will intermittently display all configuration settings.
 - c. These values and settings will continue to display and scroll until either the UP or DOWN button is pressed and will then return to normal display mode.
6. Display
 - a. The display will show information as selected in the display menu setting.
 - b. The decimal point on the display is a visual indicator of how much power is required to meet the demand. A blinking decimal indicates that the triac is being sent a signal to energize and thus turn the element on. The decimal light will blink at a faster rate as the controller is calling for more heat. When the unit is calling for full power the light is solid.
 - c. If the amount of power required exceeds the capacity of the heater, then the entire display will intermittently flash. (Note that the display will only flash when the display configuration is set to 'dSP1'.)
7. Cost Calculator-Allows the user to view the amount of power and hot water consumed and the cost of operation.
 - a. To display the Cost Calculator values, when in normal display mode press and release the UP and DOWN buttons simultaneously three times.
 - b. The display will scroll through the Cost Calculator Values since last reset
 - i. C###, where ### equals the total cost of operation
 - ii. #####, where ##### equals the total number of kW·Hrs consumed
 - iii. H0##, where ## equals water usage up to the ten thousands place, followed by h###, where ### equals water usage up to the hundreds place. Example: H012, h345 equals 12,345 gallons of water used.
 - iv. To reset these values to 0, press and hold the UP and DOWN buttons simultaneously for 5 seconds. When the display shows '0000', the cost calculator has been reset.
 - c. To enter a specific cost per kW·Hr value, while displaying the Cost Calculator values above press and release the UP and DOWN buttons simultaneously.
 - i. The display shows the cost per kW·Hr as #.### (Factory Default 0.114)
 - ii. Press the UP or DOWN button to adjust the cost per kW·Hr. Holding the UP or DOWN buttons will fast scroll.
 - iii. Press the UP or DOWN button simultaneously to lock in the cost per kW·Hr.
 - iv. Press the UP or DOWN button to return to Cost Calculator values.
 - v. Press the UP or DOWN button to return to normal display mode.
8. Error Code
 - a. Err1, indicates a failure of element #1
 - b. Err2, indicates a failure of element #2
 - c. Err3, indicates a failure of element #3
 - d. Err4, indicates a failure of element #4
 - e. Err5, indicates a failure of the inlet thermistor
 - f. Err6, indicates a failure of the outlet thermistor
 - g. Err7, indicates a failure of the display unit to communicate with the main board

SECTION V – TROUBLESHOOTING

Initial Evaluation:

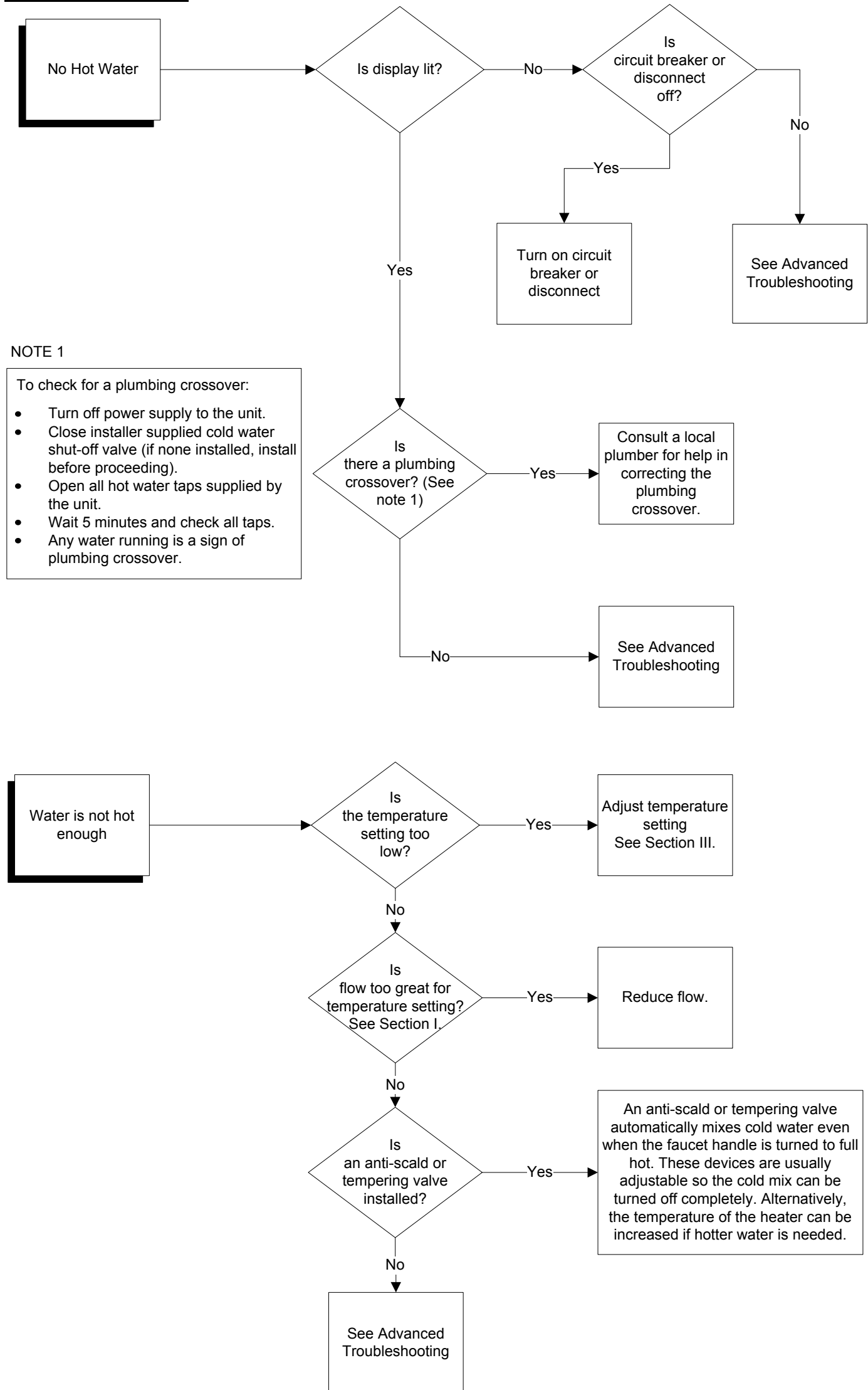

Advanced Troubleshooting:

WARNING: Serious bodily injury or death may occur if the following warnings are ignored.

- This following portion of this section is intended for use by a QUALIFIED ELECTRICIAN.
- All circuit breakers must be turned off at the main panel before the cover of the unit is removed.

This troubleshooting section will cover all the points that need to be checked from an electrical standpoint to ensure that the Gulf Coast tankless water heater is working correctly and to determine which component may need to be replaced.

Tools Required:

- Phillips screwdriver
- Clamp multi-meter able to read voltage and amperage (amperage readings require a clamp type meter).

Pre-Operational Procedures:

1. With power to the unit turned ON, verify that the configuration settings are correct in accordance with the Temperature Controller User Interface Instructions in Section IV.
2. TURN OFF POWER AT THE MAIN PANEL.
3. Remove the cover by unscrewing the screws located at the top (2) and the bottom (2) of the unit.
4. Verify that the main power feed is properly connected to the power distribution block.
5. Verify all connections are tight.

Check the Power Supply to the unit:

1. Turn on power to the unit from the main panel.
2. Using the multi-meter probes with the setting at ACV (Alternating Current Volts) in the range 250+, place one probe on the lower screw of the left hand side (L1) of the power distribution block and the other probe on the lower screw of the right hand side (L2) of the power distribution block. A voltage reading in the appropriate range (either 208V or 240V) should be indicated.
3. Write down the voltages below:

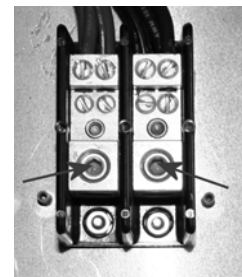

1. Volts from L1 to L2 _____
4. If no voltage is present, verify that the breakers or disconnect on the main panel have been turned on.
5. If the breakers are on and there is still no voltage present, contact an electrician to troubleshoot the feed.
6. If all voltage readings are acceptable, proceed to Check the Hi-Limit Thermostats.

Check the Hi-Limit Thermostats:

1. The unit is supplied with safety hi-limit thermostats mounted on the plate that holds the heating chamber in place. These thermostats allow the power from one phase of the terminal block to flow to the heating element. If the hi-limit thermostat fails it will not supply the heating element with power and therefore the heating element will not turn on and produce heat.
2. Using the multi-meter probes with the setting at ACV (Alternating Current Volts) in the range 250+, place one probe on the lower metal part of the thermostat and the other probe to the metal plate to ground the probe. A voltage reading in the appropriate range (110V) should be indicated since this component is being fed by

one leg of the electrical power coming off the terminal block. Perform this step on the bottom of each hi-limit thermostat then again on the top of each hi-limit thermostat.

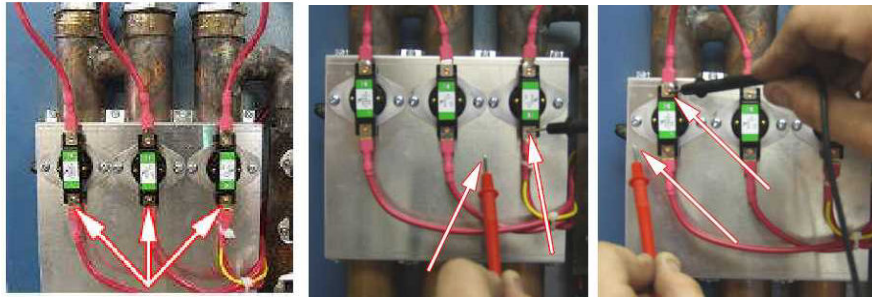

3. Write down the voltages below:

Bottom

1. Volts _____ 2. Volts _____ 3. Volts _____

Top

1. Volts _____ 2. Volts _____ 3. Volts _____

- If correct voltage is present at the bottom of the hi-limit thermostat but no voltage is present at the top of the thermostat, then that hi-limit thermostat needs to be replaced.
- If correct voltage is present on the top and bottom continue to Check the Thermistor.

Check the Thermistor:

- The thermistor is a temperature sensing device that changes resistance with changes in temperature. It is designed to register 150,000Ω at 25°C (77°F).
- At the right hand side of the temperature controller are two terminal blocks. Disconnect the wires from the uppermost terminal block. Using the multi-meter probes with the setting at OHMS or Ω, place one probe on the end of one wire and the other probe on the end of the other wire. An ohms reading consistent with the chart below for the approximate temperature of the water should be indicated. NOTE: Alligator clips should be used. Holding the wires in your hands will give a false reading. Reconnect the wires.

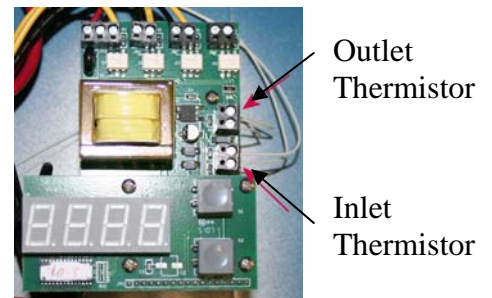

3. Write down the resistance below:

Ohms _____

- Repeat step 2 with the lower terminal block.
- Write down the resistance below:

Ohms _____

6. If either of these readings is not consistent with the chart (within ±10,000Ω), replace that thermistor.

Thermistor Chart (150,000Ω @ 25°C (77°F))

Temperature °F (°C)	Ω
50°F (10°C)	298,515
55.4°F (13°C)	258,825
60.8°F (16°C)	224,985
64.4°F (18°C)	205,215
69.8°F (21°C)	179,130
75.2°F (24°C)	156,750
80.6°F (27°C)	137,475
84.2°F (29°C)	126,120
89.6°F (32°C)	111,030
95°F (35°C)	97,965
100.4°F (38°C)	86,625
105.8°F (41°C)	76,755
109.4°F (43°C)	70,875
114.8°F (46°C)	63,015
120.2°F (49°C)	56,130

Check the Flow Switch:

1. Verify that the black plastic clip is properly secured to the flow switch.



Check the Temperature Controller:

1. At the top of the temperature controller there are 4 sets of terminal blocks. Verify the correct wiring, from left to right, the wiring should be as follows:

At the first terminal block:
RED/BLACK/YELLOW.

At the second terminal block:
BLACK/YELLOW.

For models G-21, G-24, and G-27, at the third terminal block: **BLACK/YELLOW.**

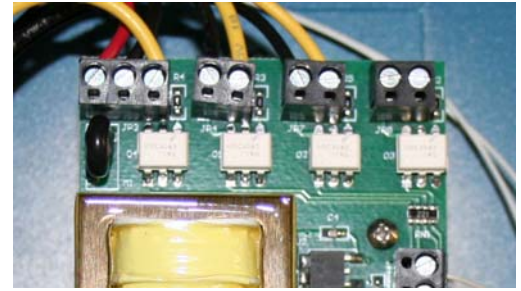

2. Using the multi-meter probes with the setting at ACV (Alternating Current Volts) in the range 250+, place one probe on the terminal block where the **RED** wire is connected and the other probe to the metal plate to ground the probe. A voltage reading in the appropriate range (110V) should be indicated.
3. Write down the voltage below:

Volts _____

4. If no voltage is present, verify that the **RED** wire in the terminal block is properly tightened and verify that the opposite end of the **RED** wire is properly inserted into the power distribution block with the larger **RED** power wire.

5. Using the multi-meter probes with the setting at ACV (Alternating Current Volts) in the range 250+, place one probe on the terminal block where the **BLACK** wire is connected and the other probe to the metal plate to ground the probe. A voltage reading in the appropriate range (110V) should be indicated. Repeat this step for each of the **BLACK** wires.

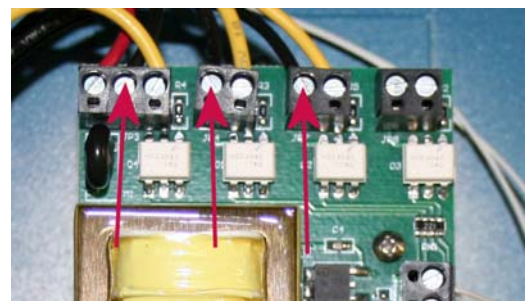

6. Write down the voltages below:

1. Volts _____ 2. Volts _____ 3. Volts _____

7. If no voltage is present, verify that the **BLACK** wires in the terminal block are properly tightened and verify that the opposite end of the **BLACK** wires are properly inserted into the power distribution block with the larger **BLACK** power wires.
8. Turn on a hot water tap preferably at the tub to ensure a good flow rate through the unit and set the temperature at the highest setting so the unit calls for full power.
9. Using the multi-meter probes with the setting at ACV (Alternating Current Volts) in the range 250+, place one probe on the terminal block where the **YELLOW** wire is connected and the other probe to the metal plate to ground the probe. A voltage reading in the appropriate range (110V) should be indicated. Repeat this step for each of the **YELLOW** wires.
10. Write down the voltages below:

1. Volts _____ 2. Volts _____ 3. Volts _____

11. If no voltage is present on any one of the **YELLOW** wires, replace the temperature controller.

Check the Triacs (Step 1):

1. The triacs are the switching mechanism for turning the heating elements on and off.
2. Turn on a hot water tap preferably at the tub to ensure a good flow rate through the unit and set the temperature at the highest setting so the unit calls for full power.

- Using the multi-meter probes with the setting at ACV (Alternating Current Volts) in the range 250+, place one probe on one of the screws where the **RED** wire is connected to the top of the heating element and the other probe to the other screw where the other **RED** wire is connected to the top of the heating element. A voltage reading in the appropriate range (either 208V or 240V) should be indicated.
- Write down the voltages below:
 - Volts _____
 - Volts _____
 - Volts _____
- If no voltage is present on any heating element, the triac connected to that element should be replaced. Note that the element should be checked for proper ohms.



Check the Heating Elements:

- To check the heating element the amperage draw from each heating element must be verified. To do this the unit must be operating.
- Turn on a hot water tap preferably at the tub to ensure a good flow rate through the unit and set the temperature at the highest setting.
- Using the clamp-on multi-meter with the setting at ACA (Alternating Current Amps), clamp the meter around the first, from right to left, of each **RED** wire that goes from the top of the safety thermostat to the top of the heating element. The reading should be in the range indicated in the element amperage chart below.
- Repeat step 3 for all the heating elements.
- Write down the amperages below:

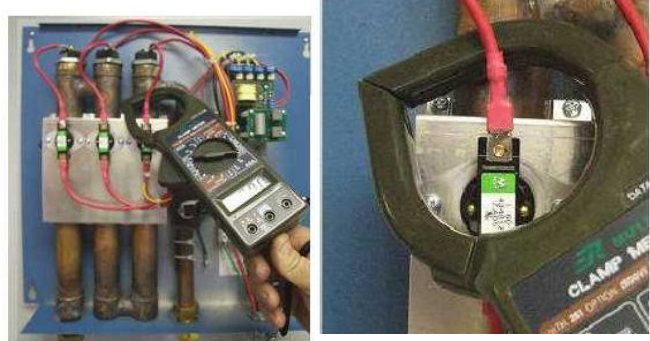

- Amps _____
- Amps _____
- Amps _____

- If any amp reading is not within the range as indicated in the chart, that heating element should be replaced.

Heating Element Amperage/Resistance Chart

Model(s)	Heating Element Amp Range	Element Resistance (Ohms)
G-27, G-18	35.6 – 39.4	6.0 – 6.7
G-24, G-16	31.7 – 35.0	6.8 – 7.6
G-21, G-14	27.7 – 30.6	7.8 – 8.6
G-11	21.8 – 24.1	9.9 – 11.0

- If all readings are within range continue to Check the Triacs (Step 2).

Check to Triacs (Step 2):

- Turn off the flow of hot water.
- Using the clamp-on multi-meter with the setting at ACA (Alternating Current Amps), clamp the meter around the first, from right to left, of each **RED** wire that goes from the top of the safety hi-limit thermostat to the top of the heating element (same as in step 3 of Check the Heating Elements). The reading should be zero.
- If any reading is not zero with the hot water turned off, then that triac should be replaced.

Contact the Factory:

- If you were unable to determine the problem from the above troubleshooting, please have the electrician contact the factory.

SECTION VI – SERVICING & REPLACEMENT OF PARTS

WARNING: Serious bodily injury or death may occur if the following warnings are ignored.

- This following portion of this section is intended for use by a QUALIFIED ELECTRICIAN OR PLUMBER.
- All circuit breakers must be turned off at the main panel before the cover of the unit is removed.
- When any maintenance is performed on the water heater that may introduce air into the unit, it is important to purge the air out of the lines before allowing the unit to power up. See Checking for Leaks and Purging Air in Section III.

Heating Element:

- Disconnect power.
 - Shut off cold water inlet and hot water outlet valves.
 - Drain unit.
 - Remove cover.
 - Disconnect **RED** power leads from the top of the element to be replaced.
 - Unscrew the element from the heating chamber coupling.
 - Install the replacement heating element by screwing it into the heating chamber coupling.
- NOTE: Verify that the o-ring is installed onto the heating element prior to installation.
- Re-connect power leads to the element terminals.
 - Re-install cover.
 - Open the cold water inlet and hot water outlet valves.
 - Bleed air from the unit. See Checking for Leaks and Purging Air in Section III.
 - Turn on power.



Hi-Limit Switch:

- Disconnect power.
 - Remove cover.
 - Disconnect power leads from the heating element and power distribution block that connect to the hi-limit switch to be replaced.
- NOTE: The replacement hi-limit switch comes with power leads attached. Power leads should not be disconnected from the hi-limit switch.
- Remove the two (2) screws securing the hi-limit switch to the heating chamber cover.
 - Remove the hi-limit switch.
 - Spread a pea sized amount of the conductive thermal paste included with the replacement kit on the back of the hi-limit switch (the portion to be installed against the heating chamber tube).
 - Install the hi-limit switch to the heating chamber cover with the two (2) screws previously removed.
 - Connect the power leads to the heating element and the power distribution block.
 - Re-install cover.
 - Turn on power.



Inlet Thermistor:

- Disconnect power.
- Remove cover.
- Disconnect inlet thermistor wires from the controller.
- Cut the tie-wrap securing the inlet thermistor and remove the inlet thermistor.
- Spread a pea sized amount of the conductive thermal paste included with the replacement kit on the inlet pipe where the replacement inlet thermistor is to be installed.
- Secure the inlet thermistor to the inlet pipe with a new tie-wrap.
- Connect the inlet thermistor wires to the controller.
- Re-install cover.
- Turn on power.

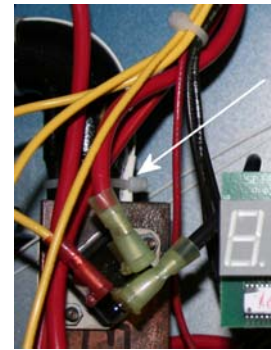
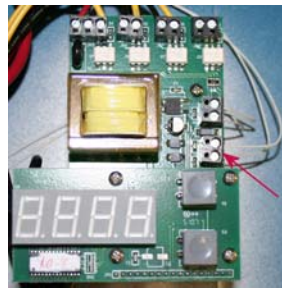

Outlet Thermistor:

- Disconnect power.
- Remove cover.
- Disconnect outlet thermistor wires from the controller.
- Cut the tie-wrap securing the outlet thermistor insulation.
NOTE: Save the insulation to cover the replacement outlet thermistor.
- Remove the aluminum tape securing the outlet thermistor and remove the outlet thermistor.
- Spread a pea sized amount of the conductive thermal paste included with the replacement kit on the outlet pipe where the replacement outlet thermistor is to be installed.
- Secure the outlet thermistor to the outlet pipe with a new piece of aluminum tape. Position the outlet thermistor such that the wires are facing towards the top.
- Secure the outlet thermistor insulation around the outlet thermistor with a new tie-wrap.
- Connect the outlet thermistor wires to the controller.
- Re-install cover.
- Turn on power.

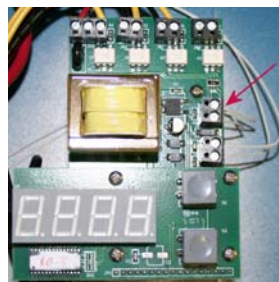

Temperature Controller:

- Disconnect power.
- Remove cover.
- Mark the wires going to the controller so they can be re-connected in the same places upon replacement.
- Disconnect all the wires from the controller.
NOTE: The display may need to be removed to access the wires from the flow meter. The display can be removed by removing the four (4) screws securing the display to the controller standoffs and then pulling the display from the socket.
- Remove the two (2) screws securing the temperature controller to the controller stand.
- Install the replacement controller with the two (2) screws removed in the last step.
- Re-connect the wires to the temperature controller in the same locations they were previously disconnected from.
- Re-install cover.
- Turn on power.

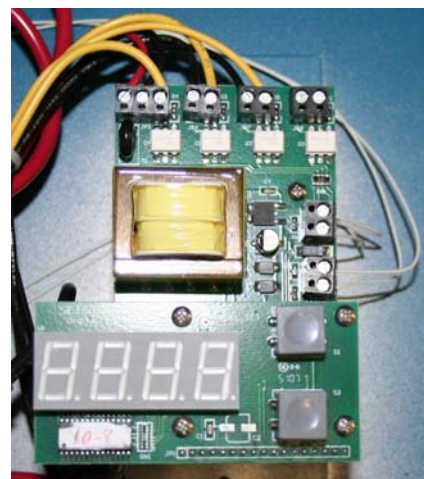

Triac:

- Disconnect power.
- Remove cover.
- Disconnect the wires from the heating element, power distribution block, and controller going to the triac to be replaced.

NOTE: Replacement triacs come with replacement wires attached.

- Remove the two (2) nuts securing the triac to the heatsink and remove the triac.
- Spread a pea sized amount of the conductive thermal paste included with the replacement kit on the back of the triac to be installed.
- Install the replacement triac to the heatsink with the two (2) nuts removed previously.
- Connect the **RED** wire to the heating element, the **BLACK** wire to the power distribution block, and the **YELLOW** wire to the controller.
- Re-install cover.
- Turn on power.

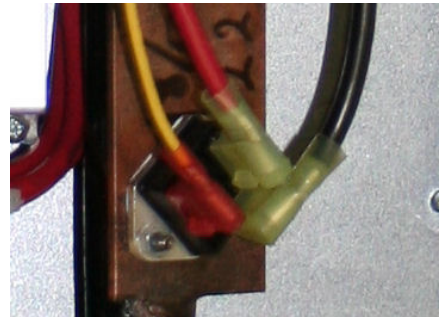

Flow Meter:

- Disconnect power.
 - Shut off cold water inlet and hot water outlet valves.
 - Drain unit.
 - Remove cover.
 - Disconnect the flow meter wires from the controller.
- NOTE: The display may need to be removed to access the wires from the flow meter. The display can be removed by removing the four (4) screws securing the display to the controller standoffs and then pulling the display from the socket.
- Disconnect the cold water supply pipe from the SharkBite fitting. See Disconnecting a Joint in Section III.
 - Unscrew the SharkBite and coupling assembly from the flow meter.

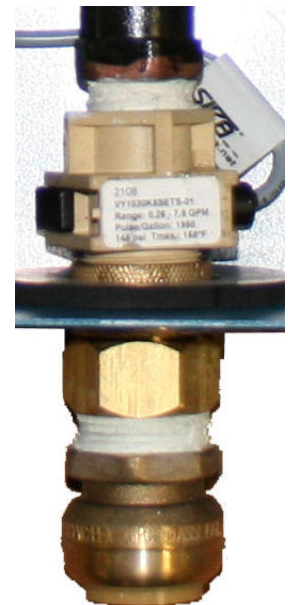

- Unscrew the flow meter from the inlet pipe.
 - Screw the replacement flow meter into the inlet pipe.
- NOTE: Pipe dope must be used to seal the connection.
- Screw the SharkBite and coupling assembly into the replacement flow meter.
 - Re-connect the cold water inlet piping to the SharkBite connector. See Installation of SharkBite in Section III.
 - Connect the flow meter wires to the controller. From left to right, **WHITE / GREEN / BROWN**.
 - Re-install cover.
 - Open the cold water inlet and hot water outlet valves
 - Bleed air from the unit. See Checking for Leaks and Purging Air in Section III.
 - Turn on power.

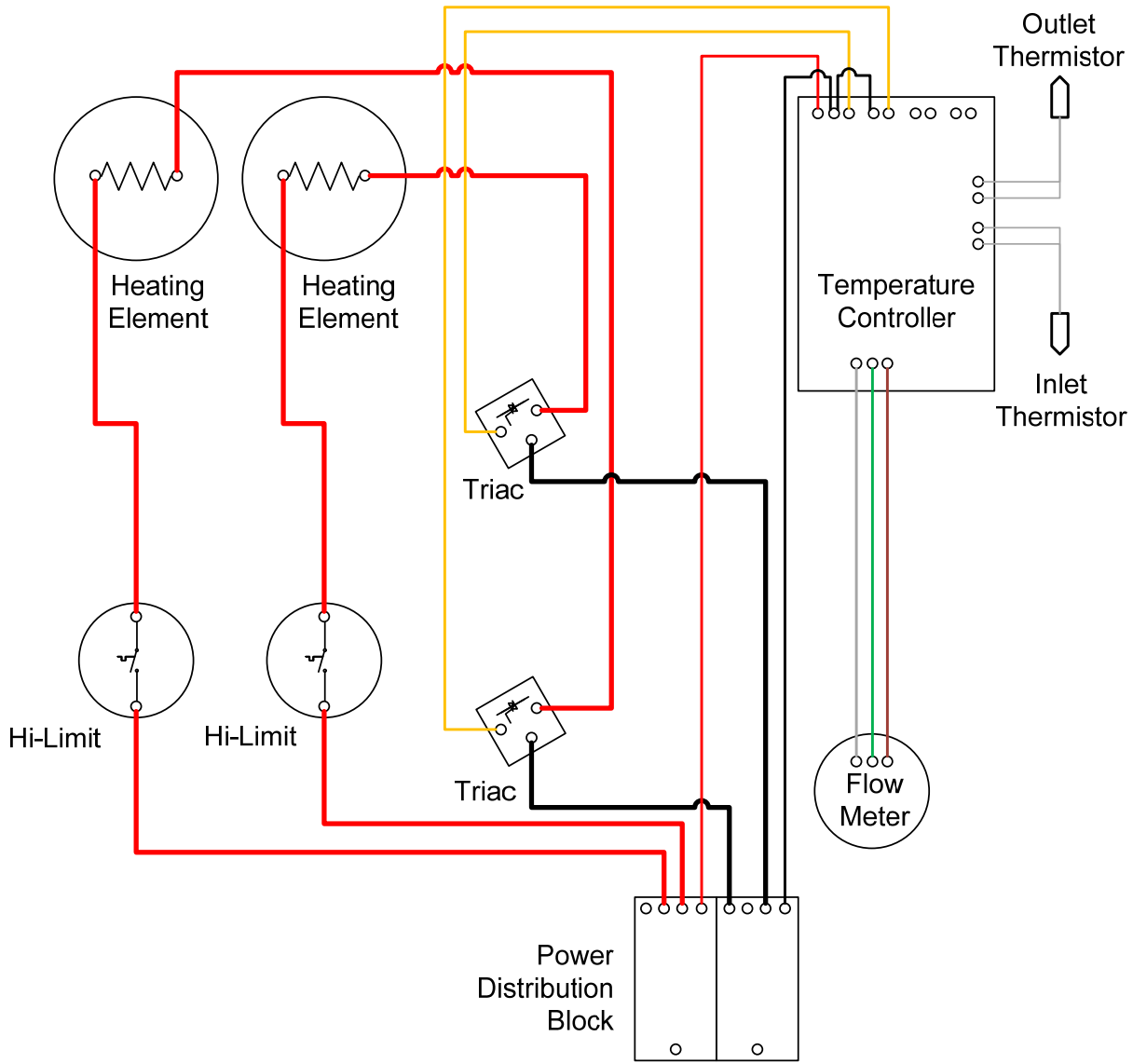

Models G-11, G-14, G-16, G-18

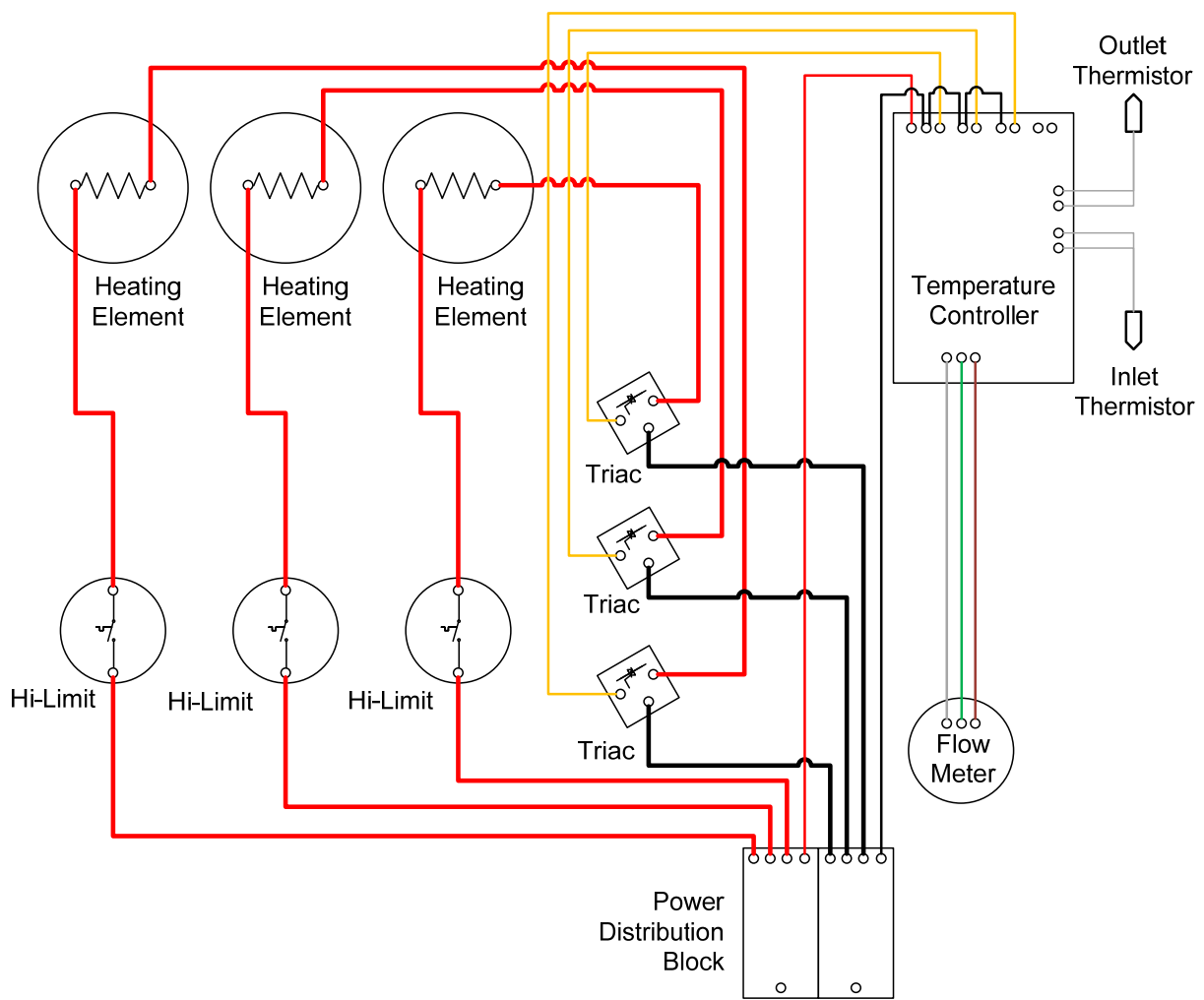

Models G-21, G-24, G-27

SECTION VII – PARTS LIST

Category	Description	Hubbell P/N
Plumbing	Shark Bite Connector-Inlet, 3/4" C x 3/4" MNPT	U134
	Shark Bite Connector-Outlet 3/4" C x 3/4" C	U016
	Shark Bite Removal Tool	EU712
	Heating Chamber: 2 Element	TK2-FM
	Heating Chamber: 3 Element	TK3-FM
	Swivel Connector 3/4" GHT x 1/2" FNPT	2142
	Filter Screen for Inlet	SCREEN TK
Triac	Triac (Supplied with wire leads)	TG40E60
Elements (with O-ring)	4500 Watts, 8.5" long	N1315-4500
	5500 Watts, 8.5" long	N1315-5500
	7000 Watts, 12" long	N1315-7000
	8000 Watts, 12" long	N1375-8000
	9000 Watts, 12" long	N1375-9000
	Extra O-Ring	O RING SGB
Electrical	Thermistor (Supplied with wire leads)	USP9509
	Auto Resetting Hi-Limit 140°F (Supplied with wire leads)	L60
	Auto Resetting Hi-Limit 199°F (Supplied with wire leads)	L93
	Temperature Control Board	TK2000
	Digital Display	TKD2000
	Power Distribution Block: 2 Pole	LBA263206
	Flow Meter (3/4" GHT x 1/2" NPT)	VTY10
	Flow Meter Sensor	VTY10 SENSOR
Wire	Wire #18 (Specify COLOR: Yellow, Red, Black)	WIRE 18 "COLOR"
	Wire #10 Red (Specify COLOR: Red, Black)	WIRE 10 "COLOR"
Miscellaneous	Front Metal Cover for Model Series 100	TK100 COVER
	Metal Base for Model Series 100	TK100 BACK
	Front Metal Cover for Model Series 200	TK200 COVER
	Metal Base for Model Series 200	TK200 BACK

Element Resistance Chart

Element P/N	Watts	Volts	Ohms		
			Min.	Nom.	Max.
N1315-4500	4500	240	12.16	12.80	13.44
N1315-5500	5000	240	10.94	11.52	12.10
N1315-7000	7000	240	7.82	8.23	8.64
N1375-8000	8000	240	6.84	7.20	7.56
N1375-9000	9000	240	6.08	6.40	6.72

SECTION VIII – WARRANTY

MANUFACTURER’S LIMITED WARRANTY

1. PRODUCT WARRANTY: Gulf Coast warrants to the original purchaser at the original address or the authorized transferee of such purchaser (collectively, the “Buyer”) the Gulf Coast Tankless Water Heater and its components as manufactured by Gulf Coast (the "Product") to be free from defects in materials and workmanship, under normal use and service for the period of time identified below beginning from the date of installation, provided that the Product is (i) installed within sixty (60) days from date of shipment from Gulf Coast and (ii) installed by a licensed electrician and plumber (*specific proof required*) and maintained in accordance with Gulf Coast's written instructions. In order for the Product warranty to become effective, the original purchaser must submit via fax, mail or website the Warranty Registration included in the Operating and Maintenance Manual supplied with each new Product.

HEATING CHAMBER:	Five (5) years
ELECTRICAL COMPONENTS:	Three (3) years
REPLACEMENT PARTS	Thirty (30) days
REFURBISHED HEATERS	One (1) year heating chamber and electrical components

SUCH WARRANTIES DO NOT COVER:

- Product failure caused by liming, sediment buildup, chemical corrosion, chlorine/chloride corrosion, or freezing.
- Product failure caused by the failure to remove air from system prior to or during operation.
- Product misuse, tampering or misapplication, accidental damage, improper installation or the application of improper voltage.
- Costs incurred for shipping, delivery, handling, and/or administrative charges.
- Product failure due to lightening, flood or other natural or manmade calamities.
- Labor charges of any kind.

THE FOREGOING WARRANTIES ARE EXCLUSIVE AND IN LIEU OF ANY OTHER WARRANTY, EXPRESSED OR IMPLIED, INCLUDING BUT NOT LIMITED TO ANY IMPLIED WARRANTY OF MERCHANTABILITY OR FITNESS FOR A PARTICULAR PURPOSE OR PATENT OR OTHER INTELLECTUAL PROPERTY RIGHT INFRINGEMENT.

Warranty Transfer Information: The warranty may be transferred to one (1) subsequent homeowner at the same physical address upon payment to Gulf Coast of a \$75.00 U.S. dollar transfer fee. Said transfer fee and second owner information must be submitted by Certified Mail within 7 days of the house sale closing or there will be no further warranty extended under any circumstances. Failure of original owner to provide 2nd owner with information in a timely fashion will not alter the requirements of this paragraph.

2. LIMITATION OF REMEDIES AND DAMAGES: Gulf Coast's liability and Buyer's exclusive remedy hereunder will be limited solely, at Gulf Coast's option, to repair or replacement by the Gulf Coast Service Center with respect to any claim made within the applicable warranty period referred to above. Without limiting the generality of the foregoing, all warranty items shall be returned by Buyer, at its sole expense, to the Gulf Coast Service Center for replacement or repair. Gulf Coast reserves the right to accept or

reject any such claim in whole or in part. Gulf Coast will not accept the return of any product without prior written approval from Gulf Coast, and all such approved returns shall be made at Buyer's sole expense. GULF COAST WILL NOT BE LIABLE, UNDER ANY CIRCUMSTANCES, FOR CONSEQUENTIAL OR INCIDENTAL DAMAGES, INCLUDING BUT NOT LIMITED TO LABOR COSTS OR LOST PROFITS RESULTING FROM THE USE OF (OR INABILITY TO USE) THE PRODUCTS OR FROM THE PRODUCTS BEING INCORPORATED IN OR BECOMING A COMPONENT OF ANY OTHER PRODUCT OR GOODS.

WARRANTY REGISTRATION

3. WARRANTY REGISTRATION: To be covered under the Gulf Coast Manufacturer's Limited Warranty you must register your product within 30 calendar days of delivery. Warranty registration using the form below may be submitted via mail to Gulf Coast Electric Heater Co., P.O. Box 288, Stratford, CT 06615-0288, or via fax 203-378-3593, or via the link on the website for Warranty Registration. THIS IS A LIMITED MANUFACTURER'S WARRANTY THAT CONVEYS BENEFITS TO THE ORIGINAL PURCHASER, SUBJECT TO THE TERMS AND CONDITIONS SET FORTH HEREIN. Keep your Product documents in a safe and secure location. Your obligation under the terms of purchase and sale require that you must return your warranty card within the prescribed timeframe (within 30 calendar days) and retain all proof of purchase, installer receipts for your warranty in order to protect your rights and obtain Manufacturer's Limited Warranty benefits. The warranty resides with the Buyer with proof of purchase not simply with an individual in possession of a Product. If the heater is to be installed in new construction at a date later than 30 days from the date of delivery, send further information when known so we may update your warranty record.

Purchaser's Information:

Name of Purchaser: _____

Installation Address: _____

City: _____ State: _____ Zip: _____ Date of Purchase: _____

Electrician Information:

Name: _____

Company: _____

Telephone: _____

License #: _____

Plumber Information:

Name: _____

Company: _____

Telephone: _____

License #: _____

4. FURTHER LIMITATIONS AND EXCLUSIONS AFFECTING YOUR

WARRANTY: This warranty is void if the product is not installed in accordance with relevant, local electrical and plumbing codes and in accordance with the installation instructions specified by the manufacturer. Local codes will override manufacturer's instructions at the time of installation and if additional installation parts are required, the costs will be the responsibility of Buyer. Above ground level installations must be protected with drip pans and drains just as the codes call for protective requirements used in regular hot water tank installations. Buyer hereby accepts the entire responsibility for ascertaining whether they have sufficient electrical power at their residence to operate our Tankless Water heaters as indicated in our specifications which are readily available at our website, in our brochures and contained in the shipping box for installers to read before installation. If Buyer has purchased without first ascertaining the cost for installation or the necessary

power available for operation, Gulf Coast at its sole and complete discretion may allow a return and grant a refund less freight and less 30% of the retail price as a restocking fee. The refund will be conditioned upon a determination by Gulf Coast after inspection of the Product being returned (either unopened or in the original shipping box and packing) that the Product has not been damaged. This request and for this reason only must be made within 30 calendar days of receipt of the Product.

AFTER 30 CALENDAR DAYS FROM DATE OF PURCHASE THERE WILL BE NO RETURNS WHATSOEVER. BUYER ACCEPTS ALL SALES AS FINAL. ANY ALTERATION TO THE PRODUCT VOIDS ALL WARRANTIES. GULF COAST IS NOT RESPONSIBLE FOR ANY OTHER CHARGE OR EXPENSE INCURRED OTHER THAN THE ORIGINAL PURCHASE PRICE OF THE PRODUCT. Gulf Coast shall not be liable for consequential, special, incidental or contingent expenses or damages arising directly or indirectly from any defect in or use of the Product nor will Gulf Coast be liable for any water damage arising directly or indirectly from the use of the Product or from the failure of or defect in any component part or connecting plumbing. Gulf Coast and Buyer agree to these and the above terms in their entirety and accept all sales as final without recourse to a credit card company and hereby agree that this Manufacturer's Limited Warranty shall be governed by the laws of the State of Connecticut any and all actions arising from or relating to this Manufacturer's Limited Warranty and any aspects of the Product shall be brought in a court of competent jurisdiction in Fairfield County, Connecticut.

WARRANTY PROCEDURE

5. Parts Replacement Procedure (Under Warranty within 3 Years)

Have your licensed electrician determine the exact parts that are defective and require replacement. Please note that technical support is available for qualified technicians only (licensed electricians and/or plumbers). Technical support that involves potentially dangerous electrical conditions is not available to an unqualified person.

When contacting Gulf Coast, please be sure that the technician has the following information on hand:

- Copy of your original Warranty Registration.
- Be sure that the technician has read the "Operation and Maintenance Manual" and has written down all the data from the Advanced Troubleshooting Section.

If, at the sole discretion of Gulf Coast, a component requires repair or replacement under the terms of this Manufacturer's Limited Warranty, the part must be purchased and paid for under our "Bill and Credit" terms and will be shipped via standard ground delivery. All shipping charges are not included and are the responsibility of the Buyer. If faster shipping service is desired, the Buyer must select and pay for same.

The replacement part purchased under our "Bill and Credit" terms is purchased via credit card and upon return of the defective parts Gulf Coast will determine the cause of failure, and if under warranty will issue a full credit less shipping charges. The returned part must be received by Gulf Coast within thirty (30) days of shipment of the replacement part. Gulf Coast will evaluate the returned part within ten (10) days, and if determined to be defective and covered under terms of this warranty, full credit for the part will be issued.

Return warranty parts to: Hubbell Electric Heater
ATTN: Tankless Warranty
45 Seymour Street
Stratford, CT 06615

NOTES

NOTES

NOTES



**The Wave of the Future
Gulf Coast Tankless Water Heater of Clearwater, Inc.**

**1600 Gulf Blvd. Suite 1112
Clearwater, FL 33637**

**Phone: (727) 517-2113
Internet: www.gulfcoasttanklesswaterheaters.com**